

CATALOG NUMBER	SURFACE FINISH	DESCRIPTION
NSAV6NW	NONE	NEW WORK STUD MOUNT BRACKET, FPTV

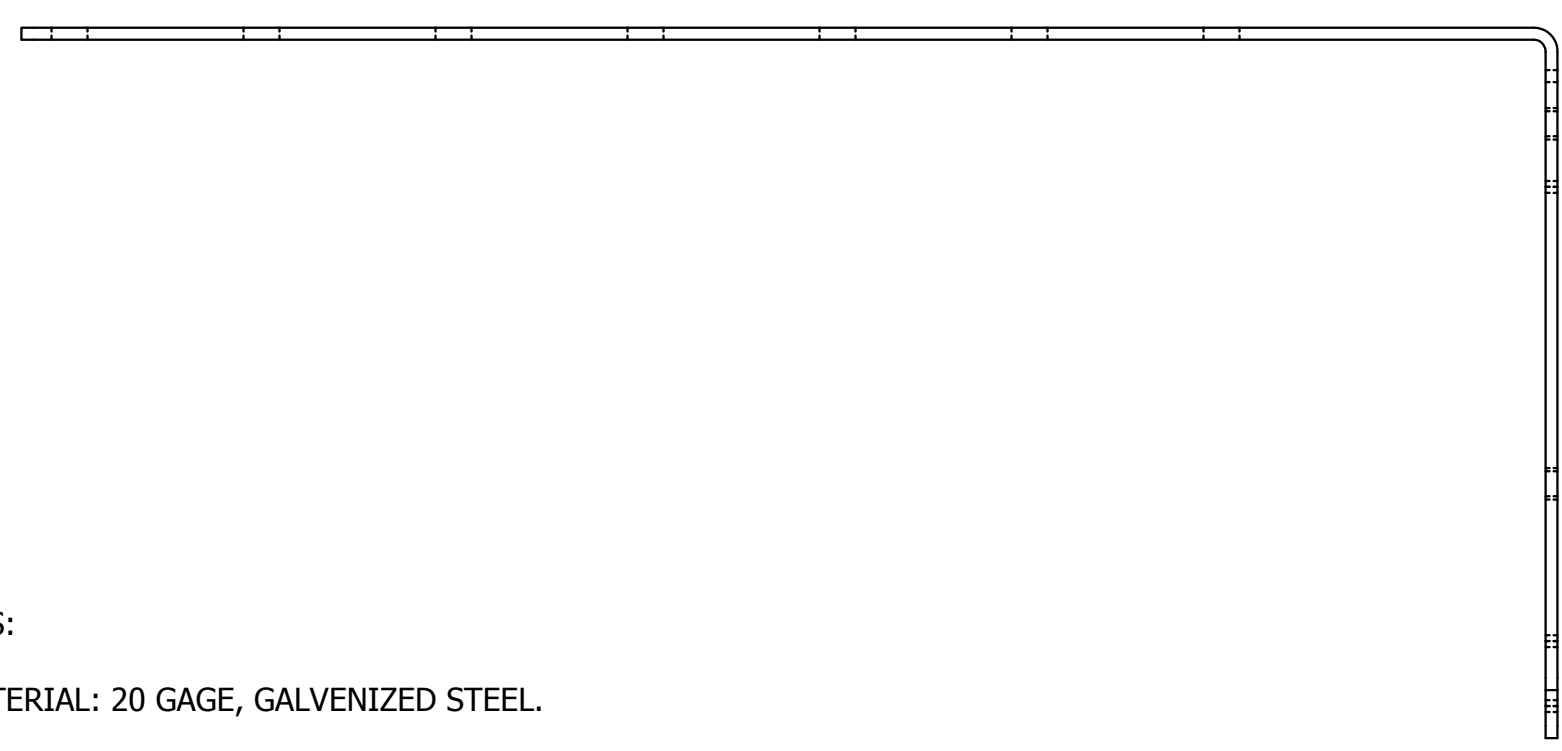
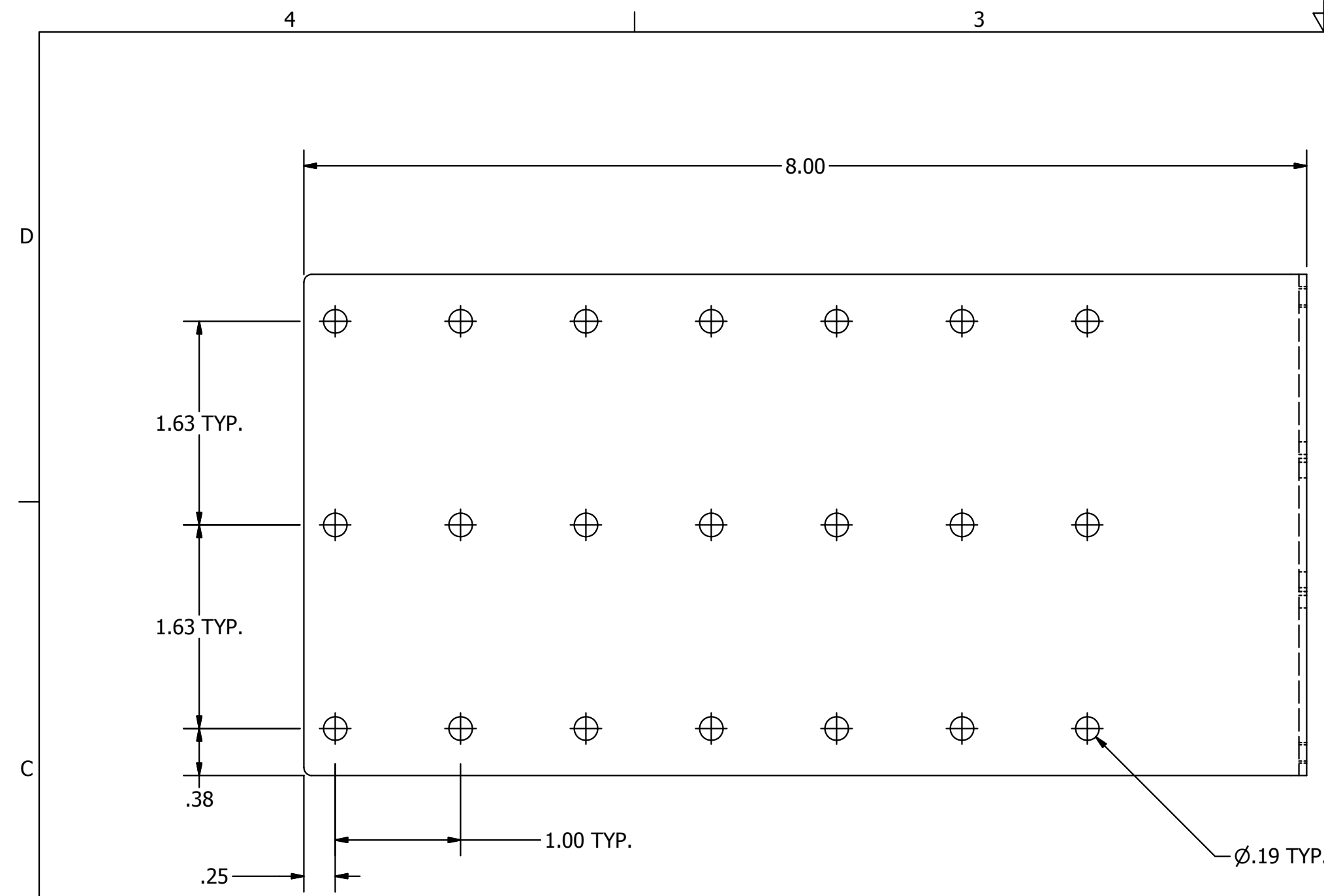
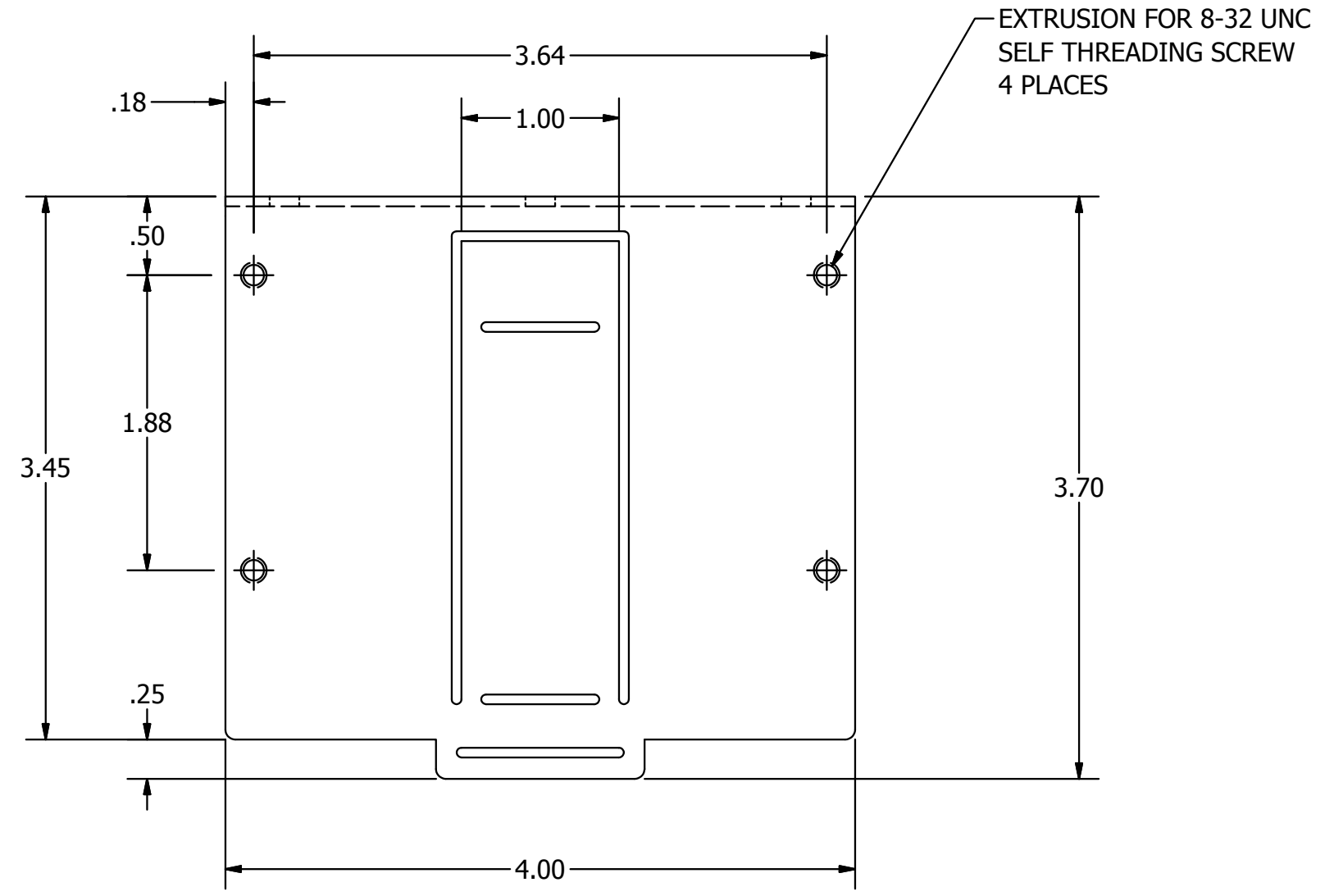
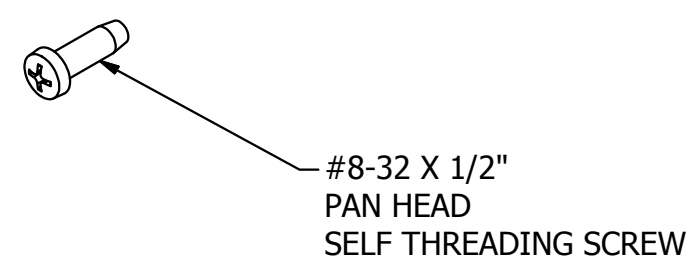
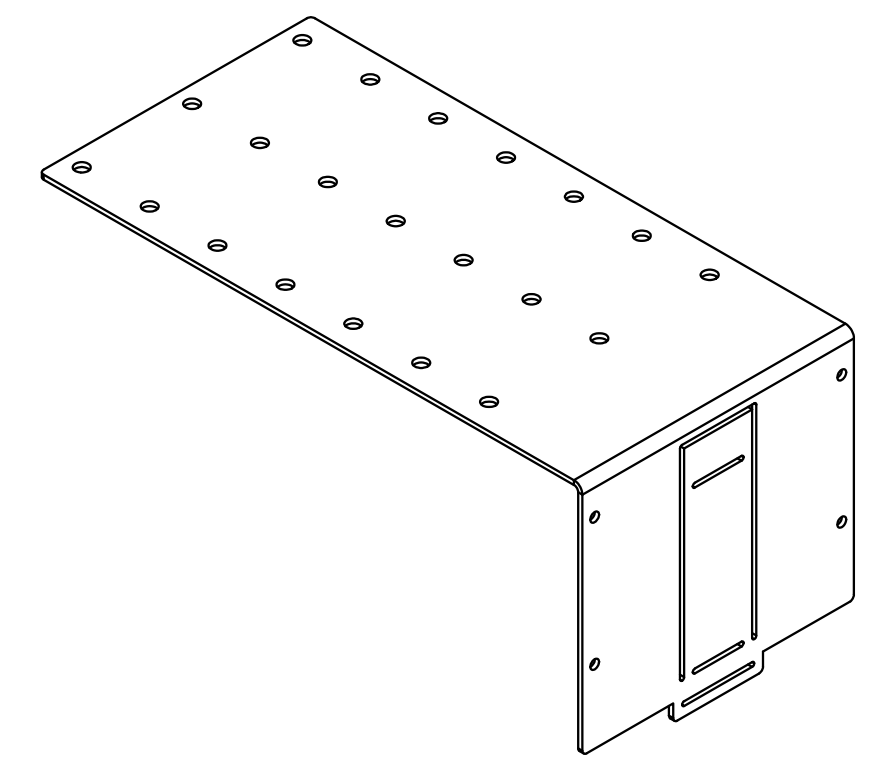

- NOTES:
- MATERIAL: 20 GAGE, GALVENIZED STEEL.
 - KIT INCLUDES, TWO BRACKETS, EIGHT #8-32 X 1/2" PAN HEAD PHILLIPS SELF THREADING SCREWS, AND ONE INSTRUCTION SHEET.
 - SPECIFICATIONS SUBJECT TO CHANGE WITHOUT NOTICE.

Created on INVENTOR	DIMENSIONING AND TOLERANCE PER ANSI Y14.5M-1982 UNLESS OTHERWISE SPECIFIED, DIMENSIONS ARE IN INCHES (MM). TOLERANCES:XX = ±.01 (.25) .XXX = ±.005 (.127) .XXXX = ±.0025 (.0635) ANGLE TOL ±1°		PROJECT REFERENCE: 044-12		Hubbell Premise Wiring HUBBELL INCORPORATED (Delaware) 23 CLARA DRIVE, SUITE 103 MYSTIC, CT 06355		
	IN ACCEPTING OUR DRAWINGS, BLUEPRINTS, OR SUPPORTING DOCUMENTATION FOR QUOTATION OR OTHER PURPOSES, YOU AGREE NOT TO DISCLOSE TO OTHERS THE IDEAS, INFORMATION, OR DESIGNS SHOWN HEREIN, AND THAT YOU WILL MAKE NO USE OF SAME WITHOUT PERMISSION		MATERIAL: SEE NOTES			TITLE: BRACKET, NEW WORK, FPTV	
			DRAWN BY: D.O'CONNOR 8/8/12		SIZE C	DRAWING NO. HWS14088C	REV. 1
			CHECKED BY: APPROVED BY: 		SCALE: SHEET 1 OF 1		

REV.	ECN	DATE	DESCRIPTION	CHG BY	APPD BY
1	17961	8/8/12	INITIAL RELEASE	DPO	